

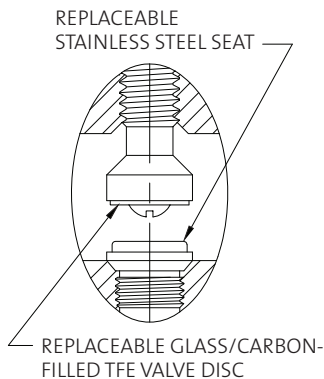

CT4890F-225WSA Steam Valve Assembly, Panel Mounted

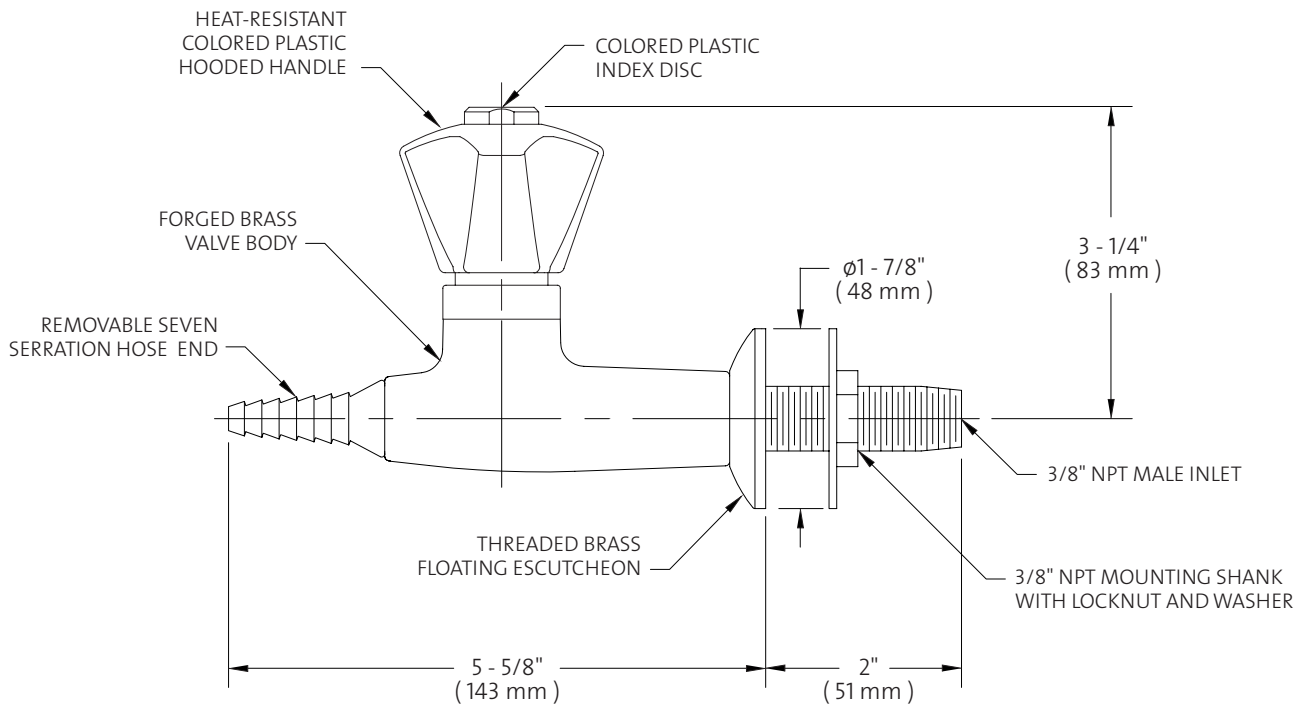

NOTES:

1. FIXTURE IS FULLY ASSEMBLED AND FACTORY TESTED AT 100 PSI AIR PRESSURE. MAXIMUM WORKING PRESSURE OF VALVE IS 20 PSI SATURATED STEAM.
2. VALVE HAS FEMALE INLET FOR CONNECTION TO SUPPLY. FLOATING ESCUTCHEON IS THREADED TO WALL TO CONCEAL ANY GAP BETWEEN VALVE AND WALL.
3. FIXTURE IS FURNISHED WITH COLORTECH POWDER-COATED FINISH.

Measurements may vary $\pm 1/4"$.

© 2008 / WaterSaver Faucet Co.