

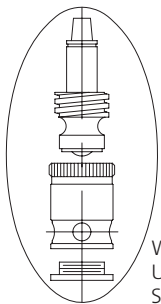

- **CT5100F-225WSA** Laboratory Water Valve Assembly, Wall Mounted, Floating Escutcheon
- **CTFS5100F-225WSA** Same as Above Except with Flow Stop

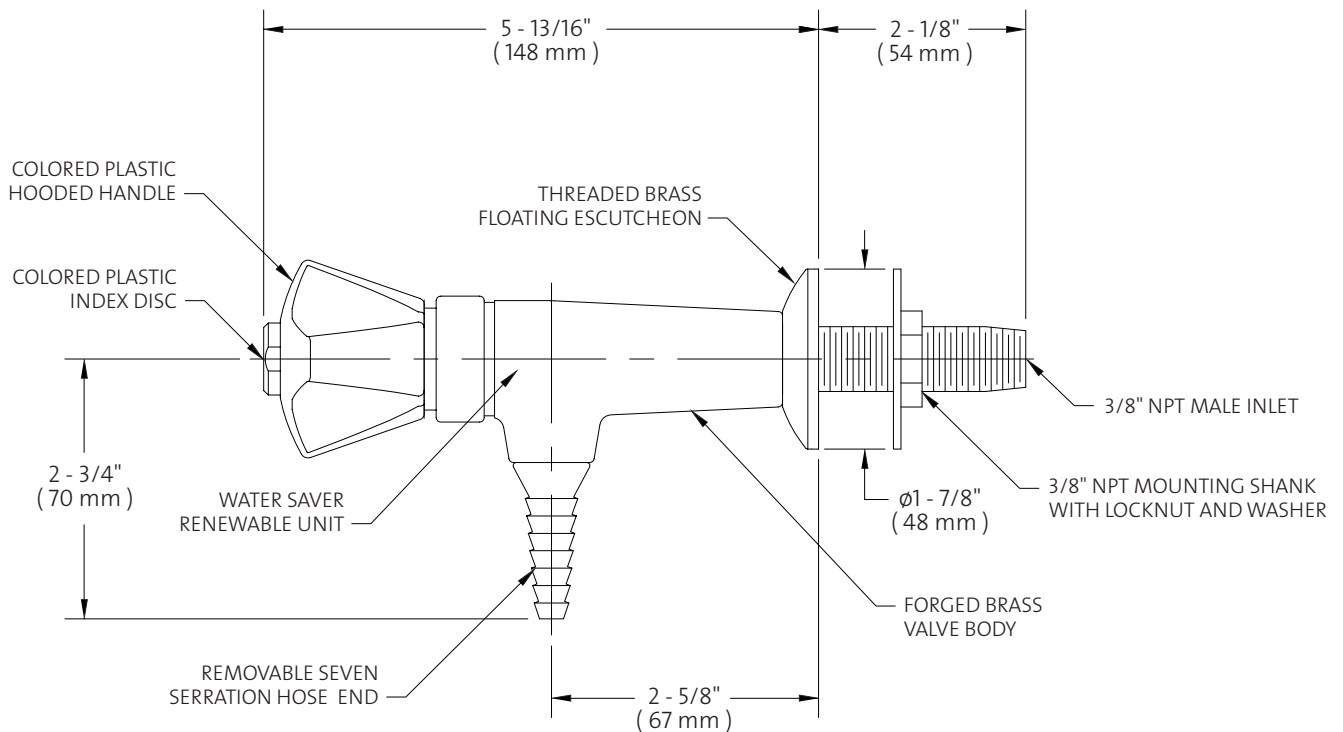

WATER SAVER RENEWABLE UNIT WITH REPLACEABLE STAINLESS STEEL SEAT



NOTES:

1. VALVE IS CERTIFIED BY CSA INTERNATIONAL TO COMPLY WITH ASME A112.18.1M AND CSA B125.1.
2. VALVE IS FULLY ASSEMBLED AND FACTORY TESTED PRIOR TO SHIPMENT.
3. FURNISHED WITH THREADED ESCUTCHEON, MOUNTING SHANK, LOCKNUT AND WASHER FOR SECURING FIXTURE TO PANEL.
4. FIXTURE IS FURNISHED WITH COLORTECH POWDER-COATED FINISH.

Measurements may vary  $\pm 1/4"$ .

© 2008 / WaterSaver Faucet Co.