

- **EW1018** Drench Hose Unit, Wall Mounted
- **EW1018BP** Drench Hose Unit, Wall Mounted, with Backflow Preventer



APPLICATION: Drench hose unit for wall mounting. Ideal for rinsing any part of user's eye, face or body. *Note: Under ANSI Z358.1 - 2004, drench hose units supplement, but do not replace, other types of emergency equipment.*

SPRAY HEAD: Single FS-Plus™ spray head. Spray head has "flip top" dust cover, internal flow control and filter to remove impurities from the water flow.

VALVE: 1/2" IPS chrome plated brass stay-open ball valve. Valve is US-made with chrome plated brass ball and Teflon® seals.

HOSE: 12' reinforced nylon retractable coiled hose. 180 PSI maximum working pressure.

MOUNTING: Bracket with spring clips holds unit on wall.

BACKFLOW PREVENTER: In-line dual backflow preventer installed on inlet of hose (EW1018BP only). *Note: Check with code authority for compliance with local plumbing code.*

SUPPLY: 3/8" NPT female inlet.

SIGN: ANSI-compliant identification sign.

QUALITY ASSURANCE: Unit is completely assembled and water tested prior to shipment.

Available Options

- **DC** Stainless steel dust cover for spray head.
- **VB** In-line vacuum breaker for installation between valve and spray head.
- **TMV** AP3600 thermostatic mixing valve precisely blends hot and cold water to deliver warm (tepid) water as required by ANSI Z358.1-2004. Refer to "Tempering Units" section for complete technical and product selection information.

- **EW1018** Drench Hose Unit, Wall Mounted
- **EW1018BP** Drench Hose Unit, Wall Mounted, with Backflow Preventer

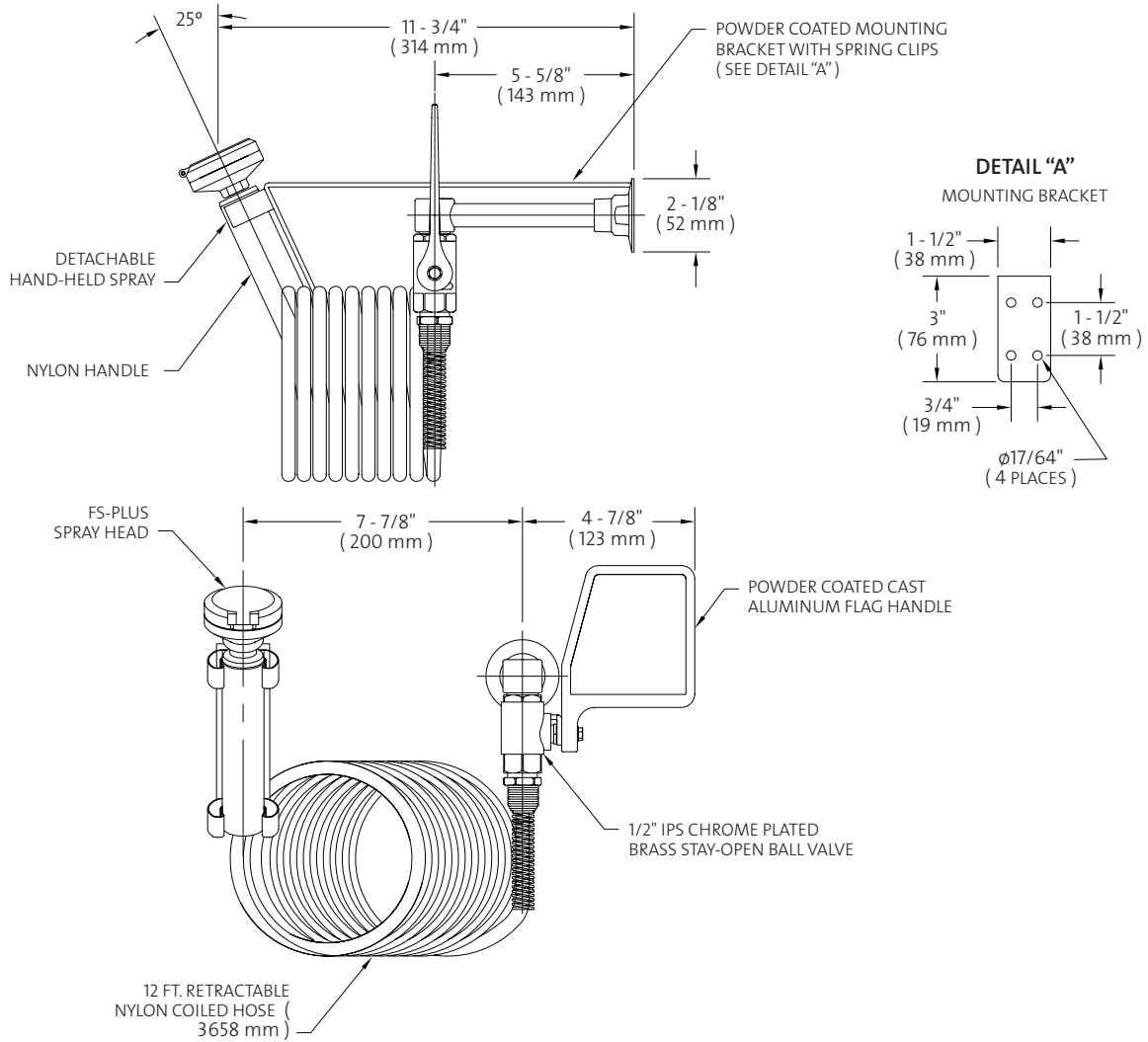

NOTES:

1. EACH GS-PLUS SPRAY HEAD HAS A "FLIP-TOP" DUST COVER, INTERNAL FLOW CONTROL AND FILTER TO REMOVE IMPURITIES FROM THE WATER FLOW.
2. HOSE SHOULD NOT BE USED IN APPLICATIONS WHERE WATER PRESSURE EXCEEDS 90 PSI. HOSE SHOULD BE INSPECTED PERIODICALLY FOR DETERIORATION.
3. IF 3/8" IPS x 2 - 1/2" MOUNTING SHANK IS REQUIRED, ADD SUFFIX "WSA".

THIS SPACE FOR ARCHITECT/ENGINEER APPROVAL

Due to continuing product improvement, the information contained in this document is subject to change without notice. All dimensions are $\pm 1/4"$ (6mm). rev. 0308

Sign Included

