

- **L2800-141FT** Laboratory Water Valve Assembly, Wall Mounted Double, Floating Escutcheon
- **L2800-110-141FT** Same as Above Except with L110 Vacuum Breaker

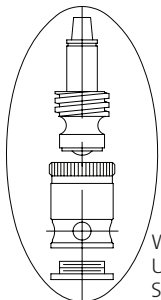

WATER SAVER RENEWABLE UNIT WITH REPLACEABLE STAINLESS STEEL SEAT

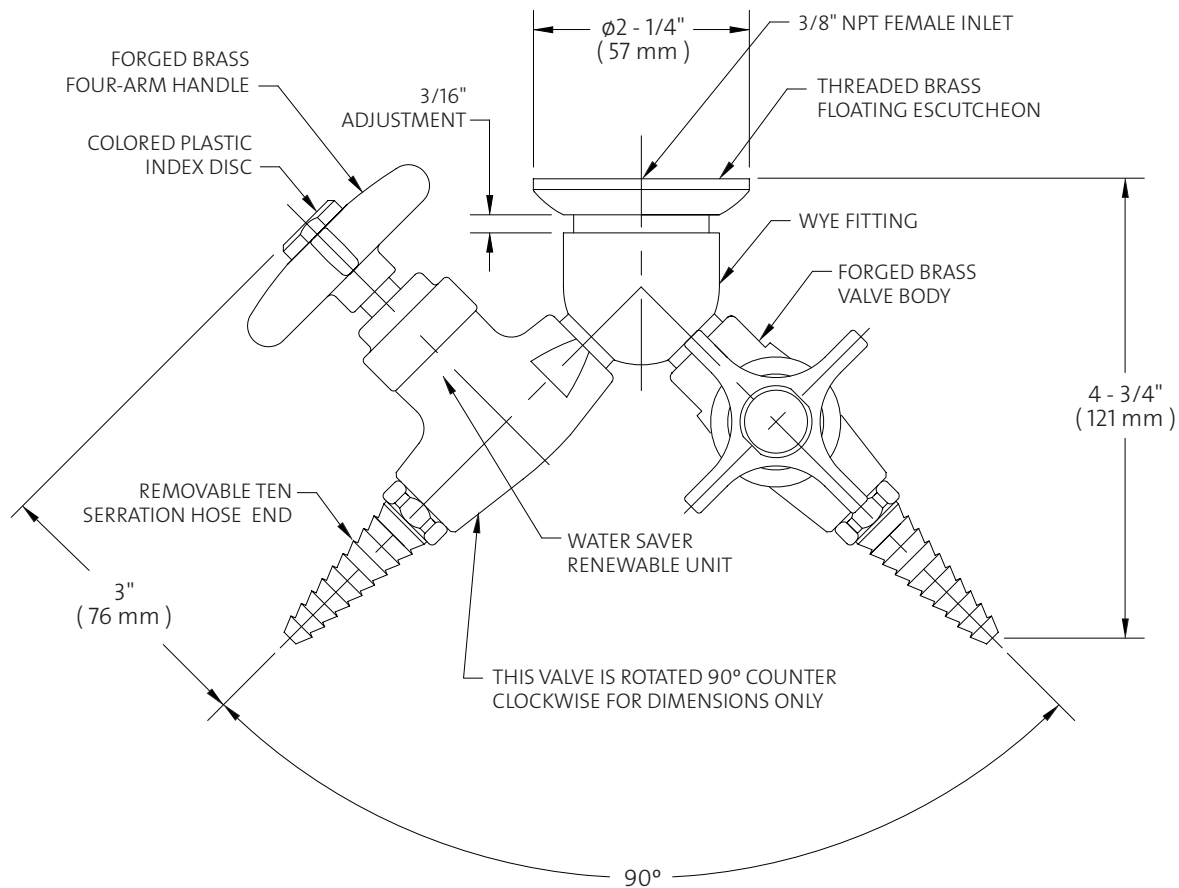

NOTES:

1. FIXTURE IS CERTIFIED BY CSA INTERNATIONAL TO COMPLY WITH ASME A112.18.1M AND CSA B125.1.
2. VALVE HAS FEMALE INLET FOR CONNECTION TO SUPPLY. FLOATING ESCUTCHEON IS THREADED TO WALL TO CONCEAL ANY GAP BETWEEN VALVE AND WALL..
3. FIXTURE IS FULLY ASSEMBLED AND FACTORY TESTED PRIOR TO SHIPMENT.

Measurements may vary  $\pm 1/4"$ .

© 2008 / WaterSaver Faucet Co.