

- **L2880-141WSA** Needle Valve Assembly, Panel/Overhead Carrier Mounted Double
- **L2880-110-141WSA** Same as Above Except with L110 Vacuum Breaker

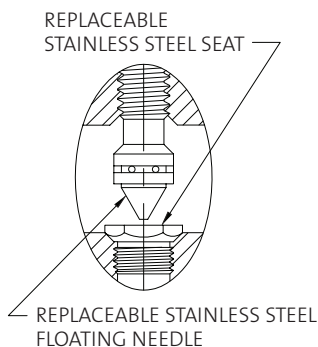

Measurements may vary $\pm 1/4$ ".

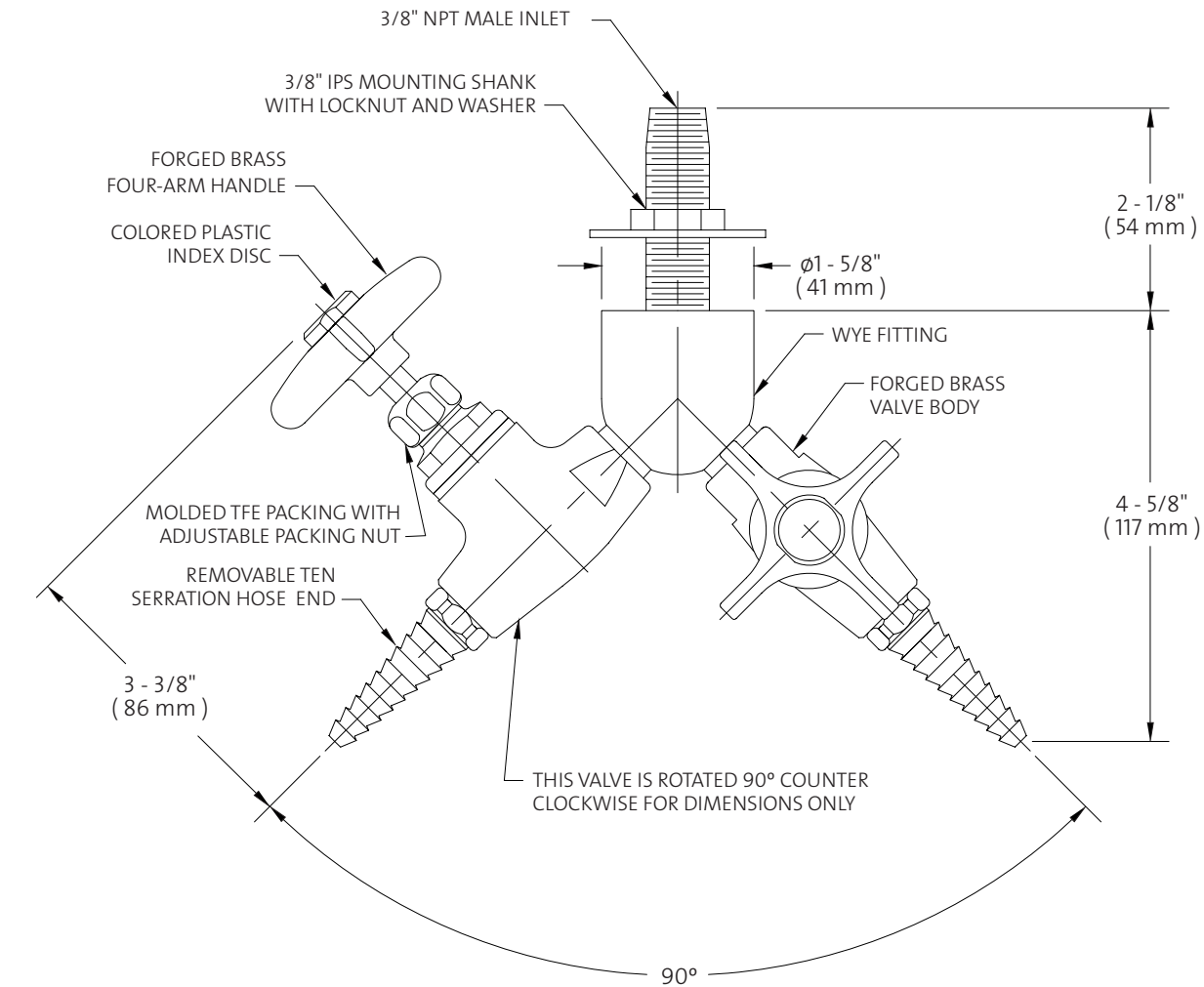

NOTES:

1. VALVE IS CERTIFIED BY CSA INTERNATIONAL TO COMPLY WITH ANSI 21.12 AND CGA 9.1.
2. FIXTURE IS FULLY ASSEMBLED AND FACTORY TESTED AT 225 PSI NITROGEN PRESSURE. MAXIMUM WORKING PRESSURE IS 150 PSI.
3. SPECIFY IF CLEANING FOR OXYGEN AND HIGH PURITY GASES IS REQUIRED.

© 2008 / WaterSaver Faucet Co.