

○ **L2892** Steam Valve, Straight Pattern, Angle Serrated Hose End

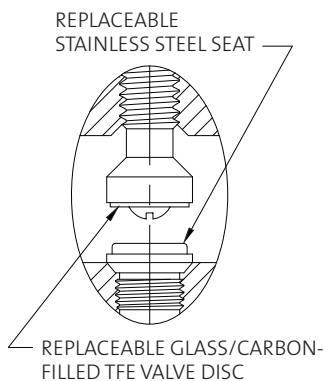
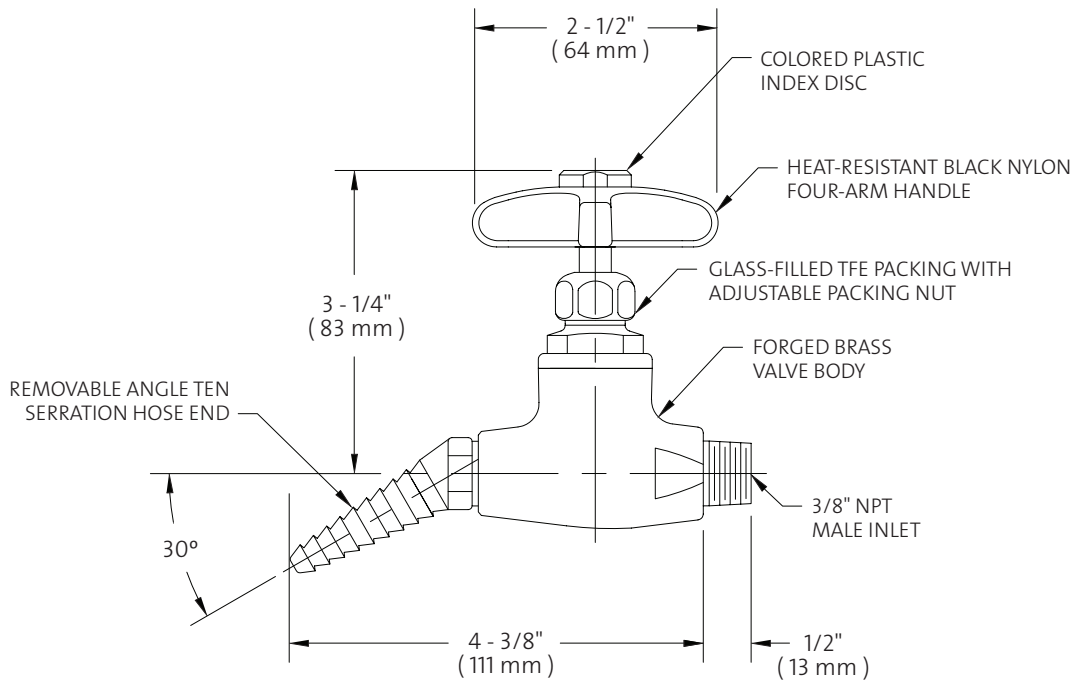

NOTE:

1. VALVE IS FULLY ASSEMBLED AND FACTORY TESTED AT 100 PSI AIR PRESSURE. MAXIMUM WORKING PRESSURE OF VALVE IS 20 PSI SATURATED STEAM.

Measurements may vary  $\pm 1/4"$ .

© 2008 / WaterSaver Faucet Co.