

- **L3100-141WSA** Laboratory Water Valve Assembly, Panel/Overhead Carrier Mounted Double
- **L3100-110-141WSA** Same as Above Except with L110 Vacuum Breaker

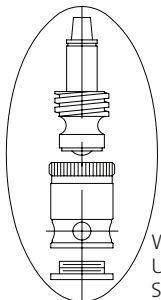

WATER SAVER RENEWABLE UNIT WITH REPLACEABLE STAINLESS STEEL SEAT

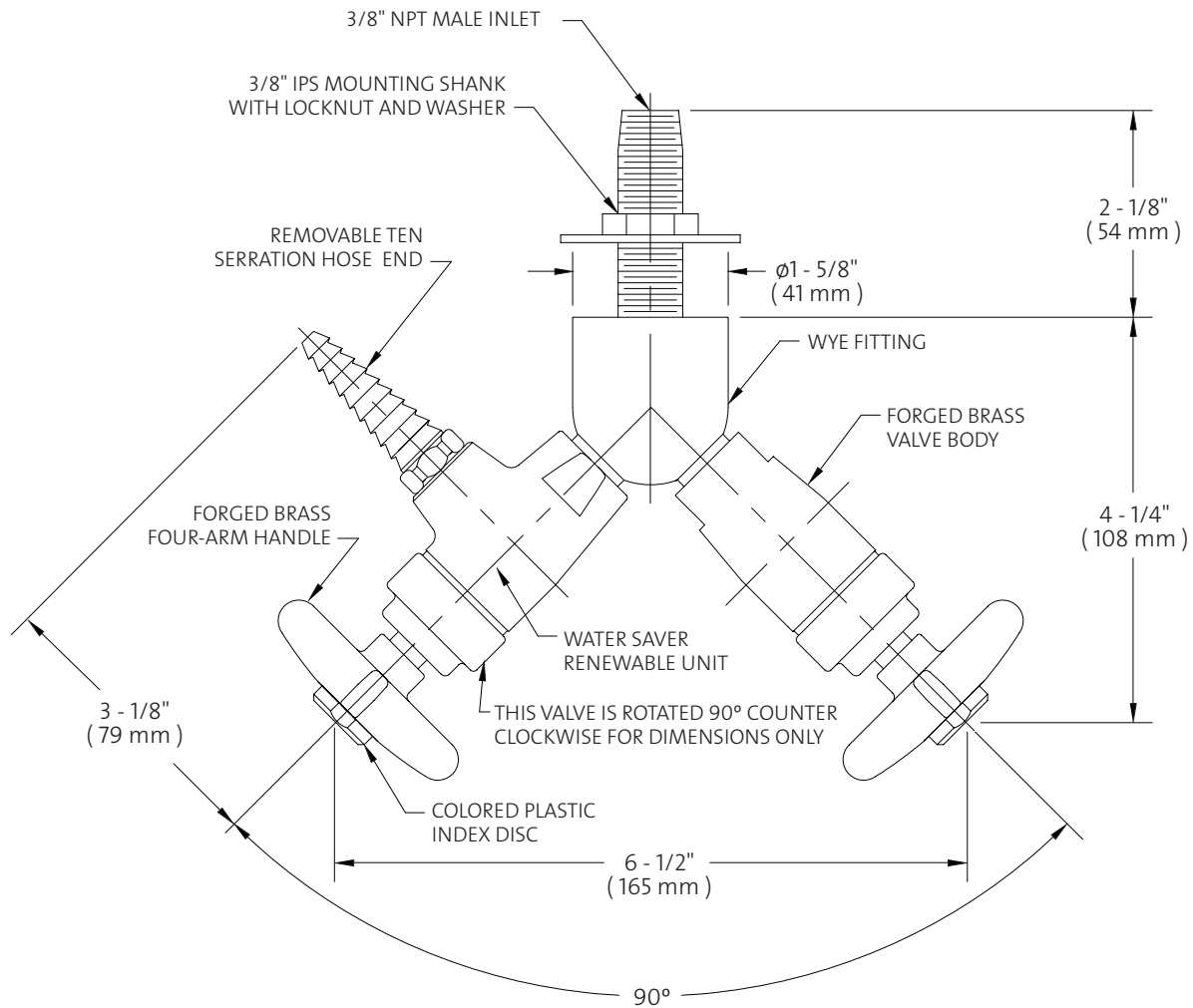

NOTES:

1. FIXTURE IS CERTIFIED BY CSA INTERNATIONAL TO COMPLY WITH ASME A112.18.1M AND CSA B125.1.
2. FIXTURE IS FULLY ASSEMBLED AND FACTORY TESTED PRIOR TO SHIPMENT.

Measurements may vary  $\pm 1/4$ ".

© 2008 / WaterSaver Faucet Co.