

- **L3100** Laboratory Water Valve, Angle Pattern
- **L3100-110** Same as Above Except with L110 Vacuum Breaker

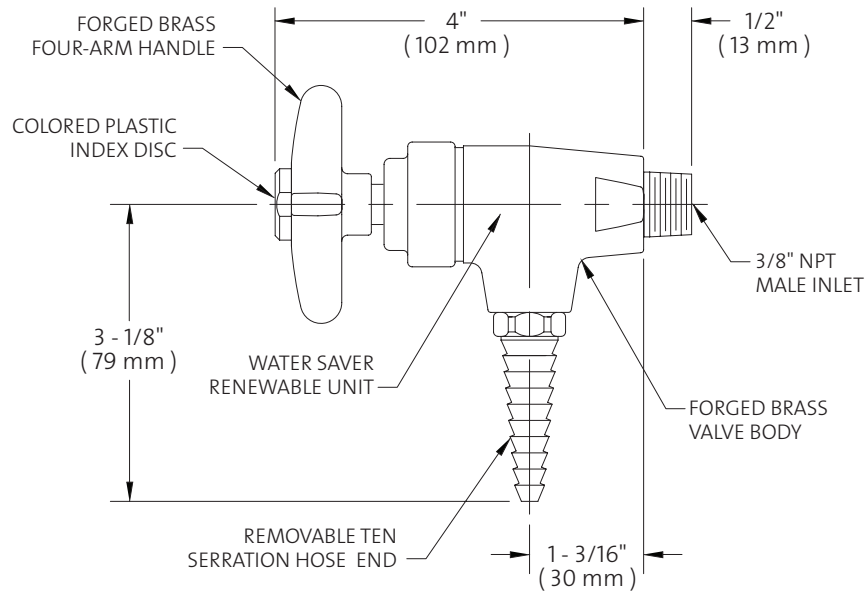

L3100

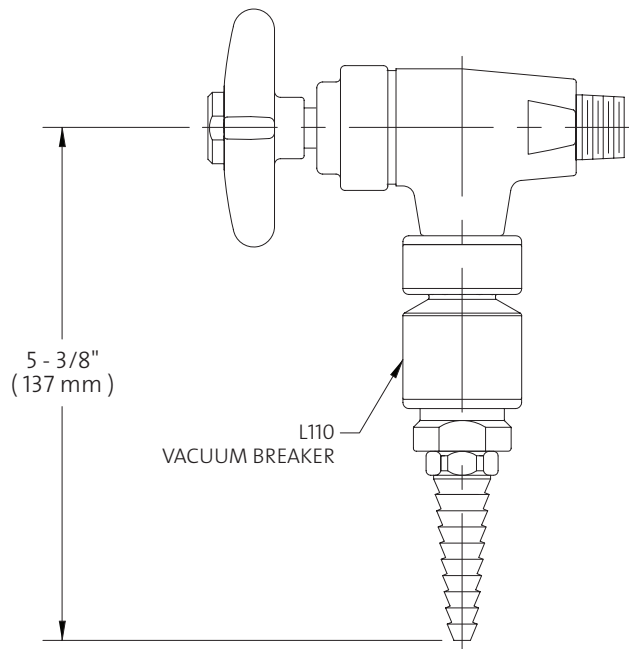

L3100-110

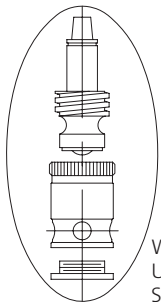

WATER SAVER RENEWABLE UNIT WITH REPLACEABLE STAINLESS STEEL SEAT



NOTES:

1. VALVE IS CERTIFIED BY CSA INTERNATIONAL TO COMPLY WITH ASME A112.18.1M AND CSA B125.1.
2. VACUUM BREAKER IS CERTIFIED TO COMPLY WITH ASSE 1035.

Measurements may vary $\pm 1/4$ ".

© 2008 / WaterSaver Faucet Co.