

- **L3180-141FT** Needle Valve Assembly, Wall Mounted Double, Floating Escutcheon
- **L3180-110-141FT** Same as Above Except with L110 Vacuum Breaker

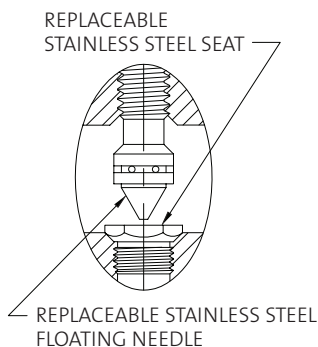
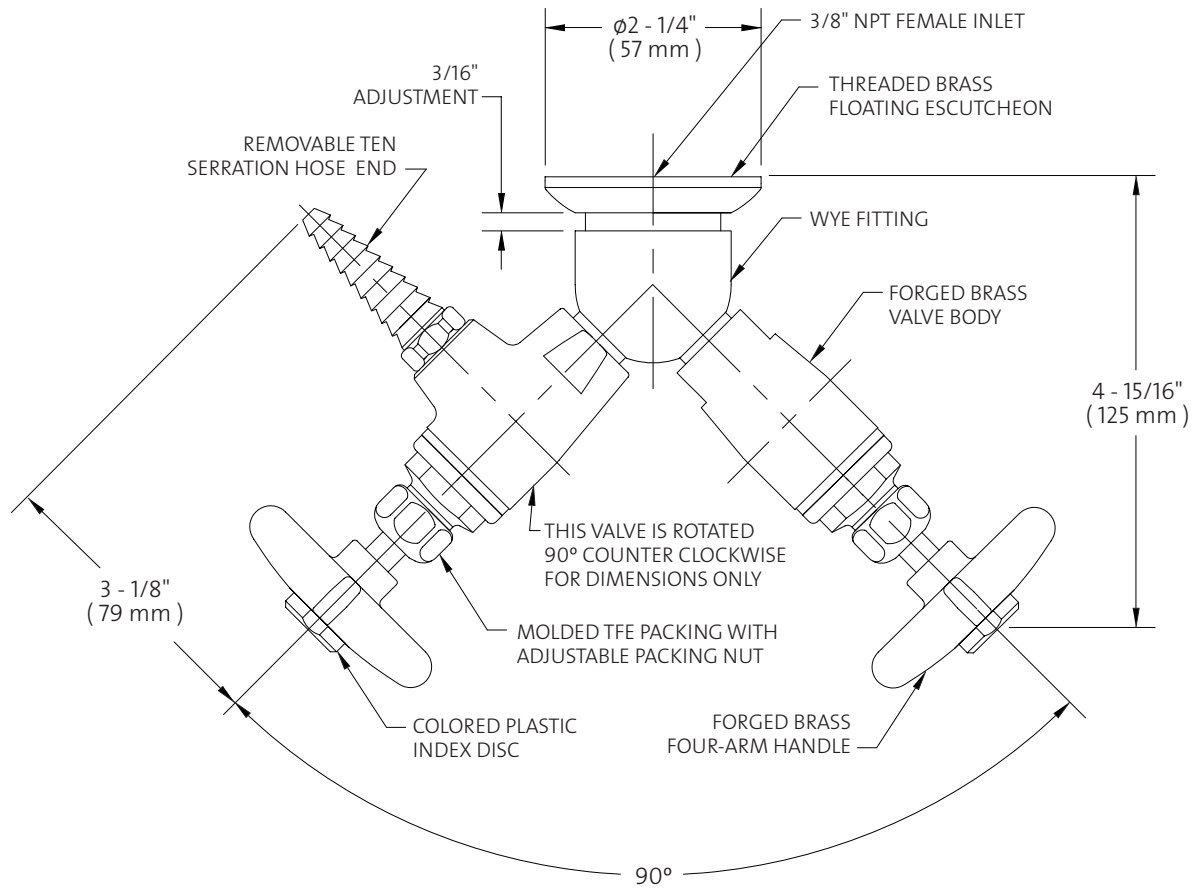

Measurements may vary $\pm 1/4$ ".

NOTES:

1. VALVE IS CERTIFIED BY CSA INTERNATIONAL TO COMPLY WITH ANSI 21.12 AND CGA 9.1.
2. VALVE HAS FEMALE INLET FOR CONNECTION TO SUPPLY. FLOATING ESCUTCHEON IS THREADED TO WALL TO CONCEAL ANY GAP BETWEEN VALVE AND WALL.
3. VALVE IS FULLY ASSEMBLED AND FACTORY TESTED AT 225 PSI NITROGEN PRESSURE. MAXIMUM WORKING PRESSURE IS 150 PSI.
4. SPECIFY IF CLEANING FOR OXYGEN AND HIGH PURITY GASES IS REQUIRED.

