

○ **L4880F-225WSA** Needle Valve Assembly, Panel/Overhead Carrier Mounted

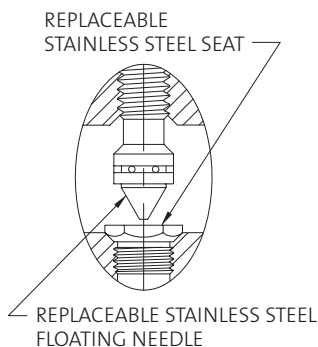
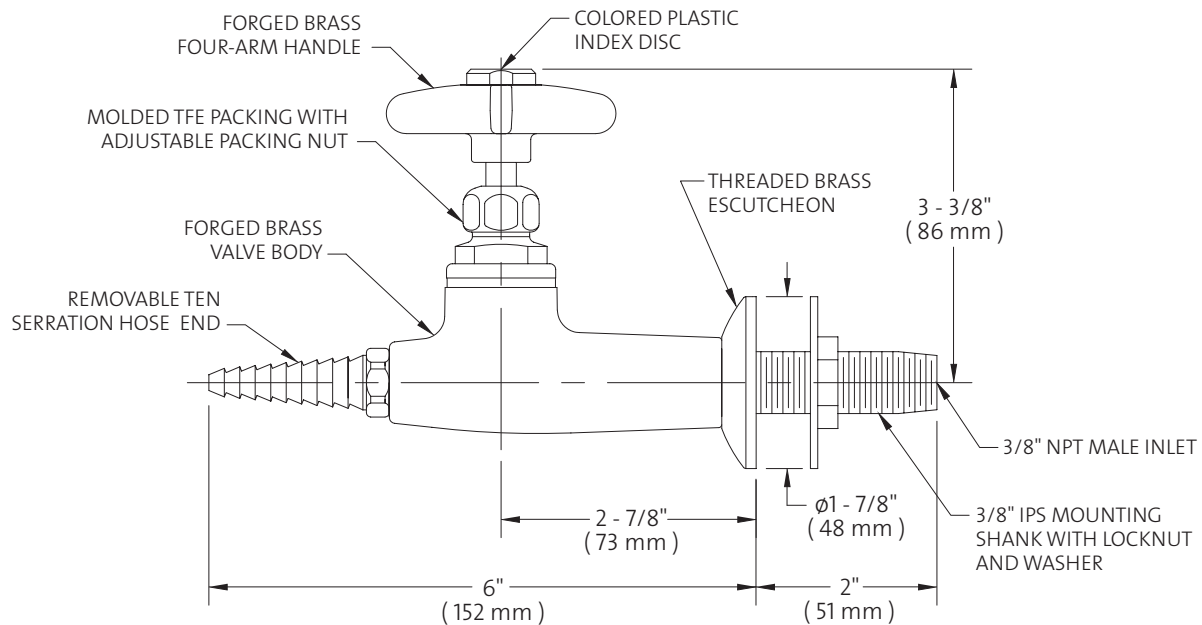

NOTES:

1. VALVE IS CERTIFIED BY CSA INTERNATIONAL TO COMPLY WITH ANSI 21.12 AND CGA 9.1.
2. FURNISHED WITH THREADED ESCUTCHEON, MOUNTING SHANK, LOCKNUT AND WASHER FOR SECURING FIXTURE TO PANEL.
3. FIXTURE IS FULLY ASSEMBLED AND FACTORY TESTED AT 225 PSI NITROGEN PRESSURE. MAXIMUM WORKING PRESSURE IS 150 PSI.
4. SPECIFY IF CLEANING FOR OXYGEN AND HIGH PURITY GASES IS REQUIRED.

Measurements may vary $\pm 1/4$ ".

© 2008 / WaterSaver Faucet Co.