

### ○ L4880FT-325 Needle Valve Assembly, Wall Mounted, Floating Escutcheon

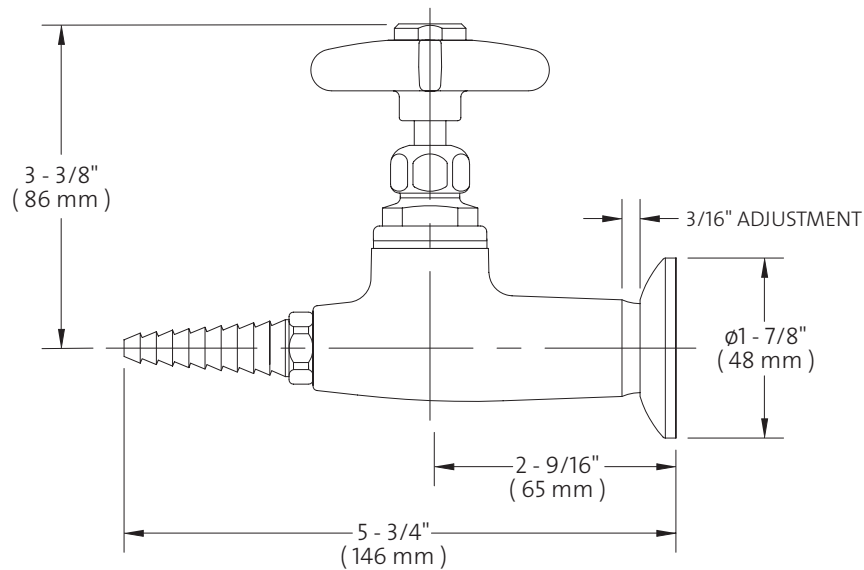

REPLACEABLE  
STAINLESS STEEL SEAT

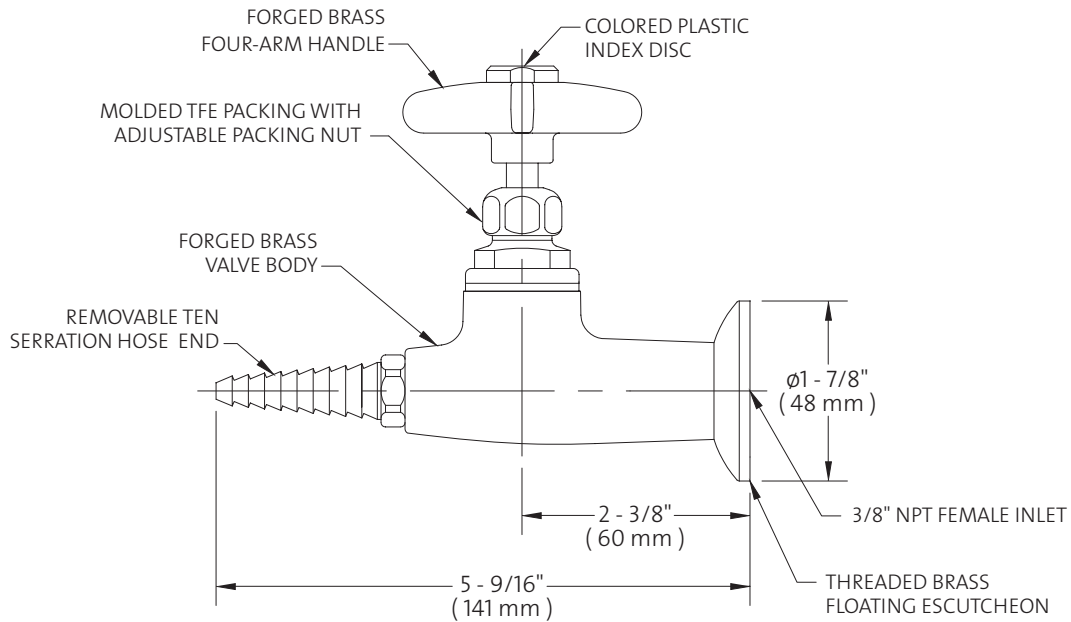
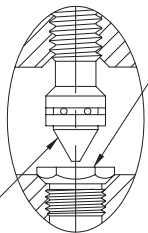

REPLACEABLE STAINLESS STEEL  
FLOATING NEEDLE

#### NOTES:

1. VALVE IS CERTIFIED BY CSA INTERNATIONAL TO COMPLY WITH ANSI 21.12 AND CGA 9.1.
2. VALVE HAS FEMALE INLET FOR CONNECTION TO SUPPLY. FLOATING ESCUTCHEON IS THREADED TO WALL TO CONCEAL ANY GAP BETWEEN VALVE AND WALL.
3. VALVE IS FULLY ASSEMBLED AND FACTORY TESTED AT 225 PSI NITROGEN PRESSURE. MAXIMUM WORKING PRESSURE IS 150 PSI.
4. SPECIFY IF CLEANING FOR OXYGEN AND HIGH PURITY GASES IS REQUIRED.



Measurements may vary  $\pm 1/4$ ".

© 2008 / WaterSaver Faucet Co.