

- **L4892F-225WSA** Steam Valve Assembly, Panel/Overhead Carrier Mounted, Angle Serrated Hose End
- **L4890F-225WSA** Same as Above Except with Straight Serrated Hose End

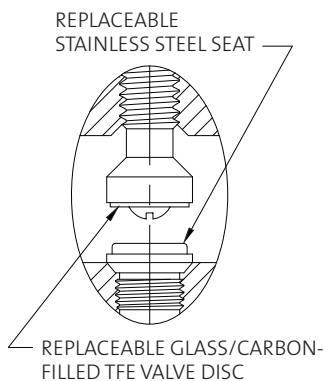
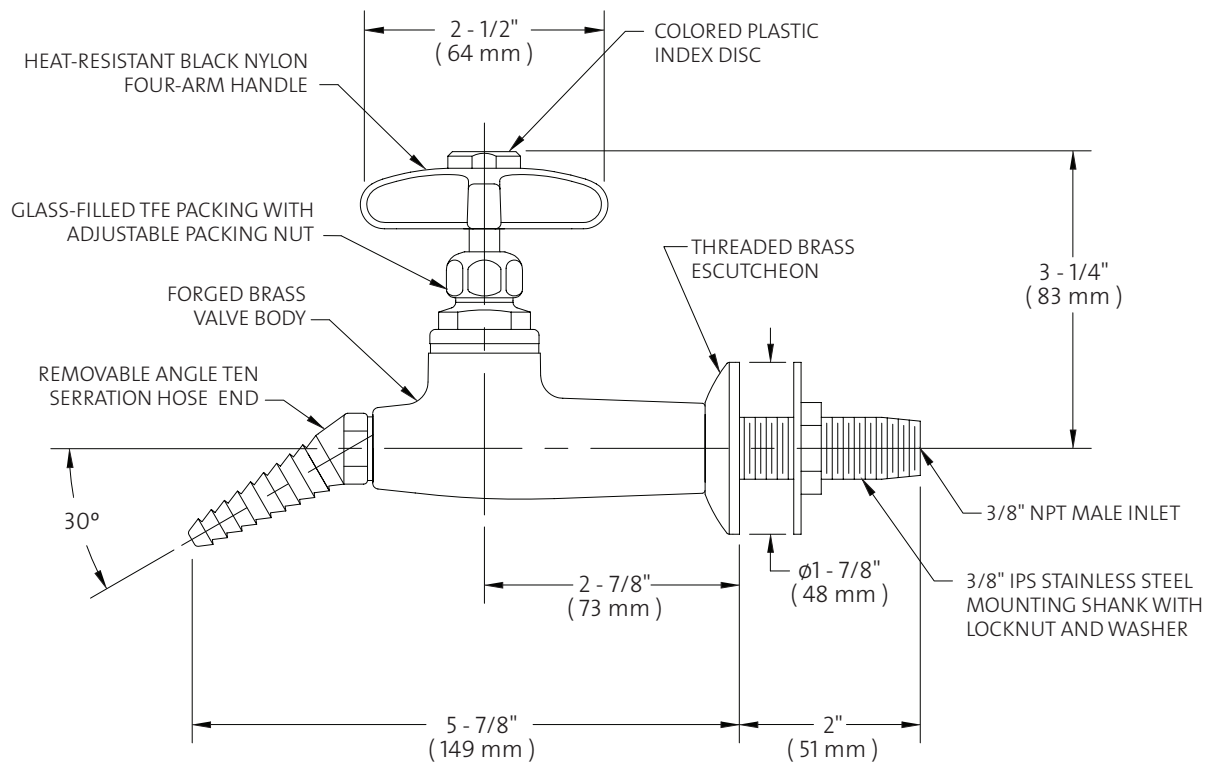

NOTE:

1. FIXTURE IS FULLY ASSEMBLED AND FACTORY TESTED AT 100 PSI AIR PRESSURE. MAXIMUM WORKING PRESSURE OF VALVE IS 20 PSI SATURATED STEAM.

Measurements may vary $\pm 1/4$ ".

© 2008 / WaterSaver Faucet Co.