

**L5300WSA** Combination Fixture for Cold Water and Gas, Heavy Duty

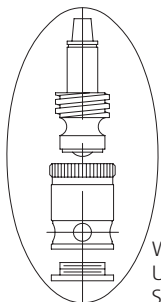

WATER SAVER RENEWABLE UNIT WITH REPLACEABLE STAINLESS STEEL SEAT

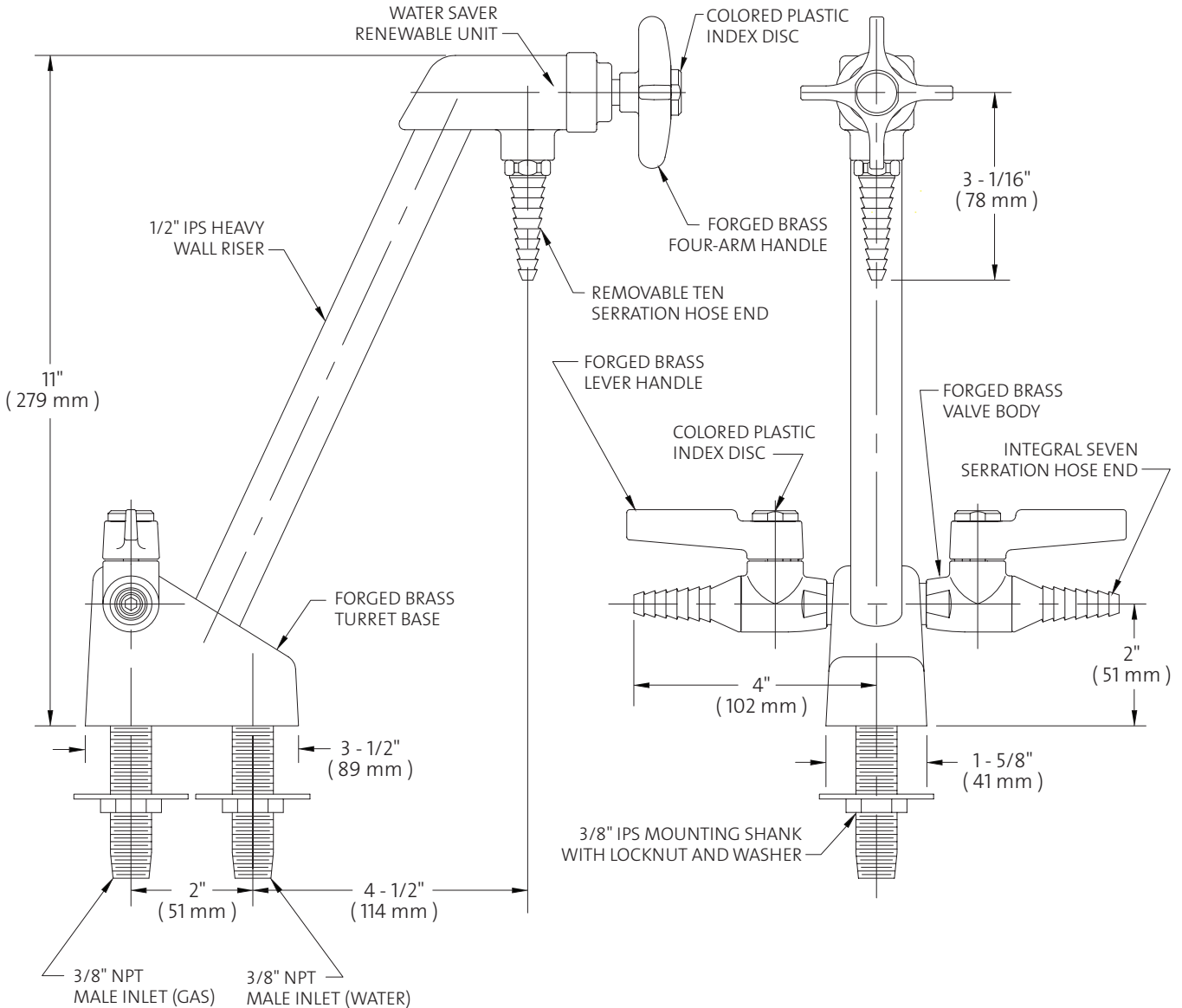

NOTES:

1. FIXTURE MAY BE USED FOR COLD WATER AND NATURAL GAS, AIR OR VACUUM.
2. UNLESS OTHERWISE SPECIFIED, FIXTURE IS FURNISHED WITH INDEX DISCS FOR GAS.
3. WATER VALVE IS CERTIFIED BY CSA INTERNATIONAL TO COMPLY WITH ASME A112.18.1M AND CSA B125.1.
4. LABORATORY BALL VALVES ARE CERTIFIED BY CSA INTERNATIONAL TO COMPLY WITH ANSI Z21.15 AND CGA 9.1.
5. FIXTURE IS FULLY ASSEMBLED AND FACTORY TESTED PRIOR TO SHIPMENT.

Measurements may vary  $\pm 1/4$ ".

© 2008 / WaterSaver Faucet Co.