

○ L740FCN-774VR-QR Pressure Regulator Fixture, Fume Hood Mounted

THIS FIXTURE IS FOR USE ON PURE GAS SYSTEMS, INCLUDING OXYGEN. THE FOLLOWING GASES MAY BE USED WITH THIS FIXTURE: AIR, ARGON, CARBON DIOXIDE, HELIUM, NITROGEN, NITROUS OXIDE AND OXYGEN. DO NOT USE WHERE PRESSURE OR TEMPERATURE CAN EXCEED RATED OPERATING CONDITIONS.

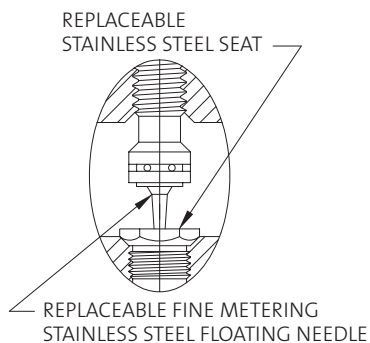
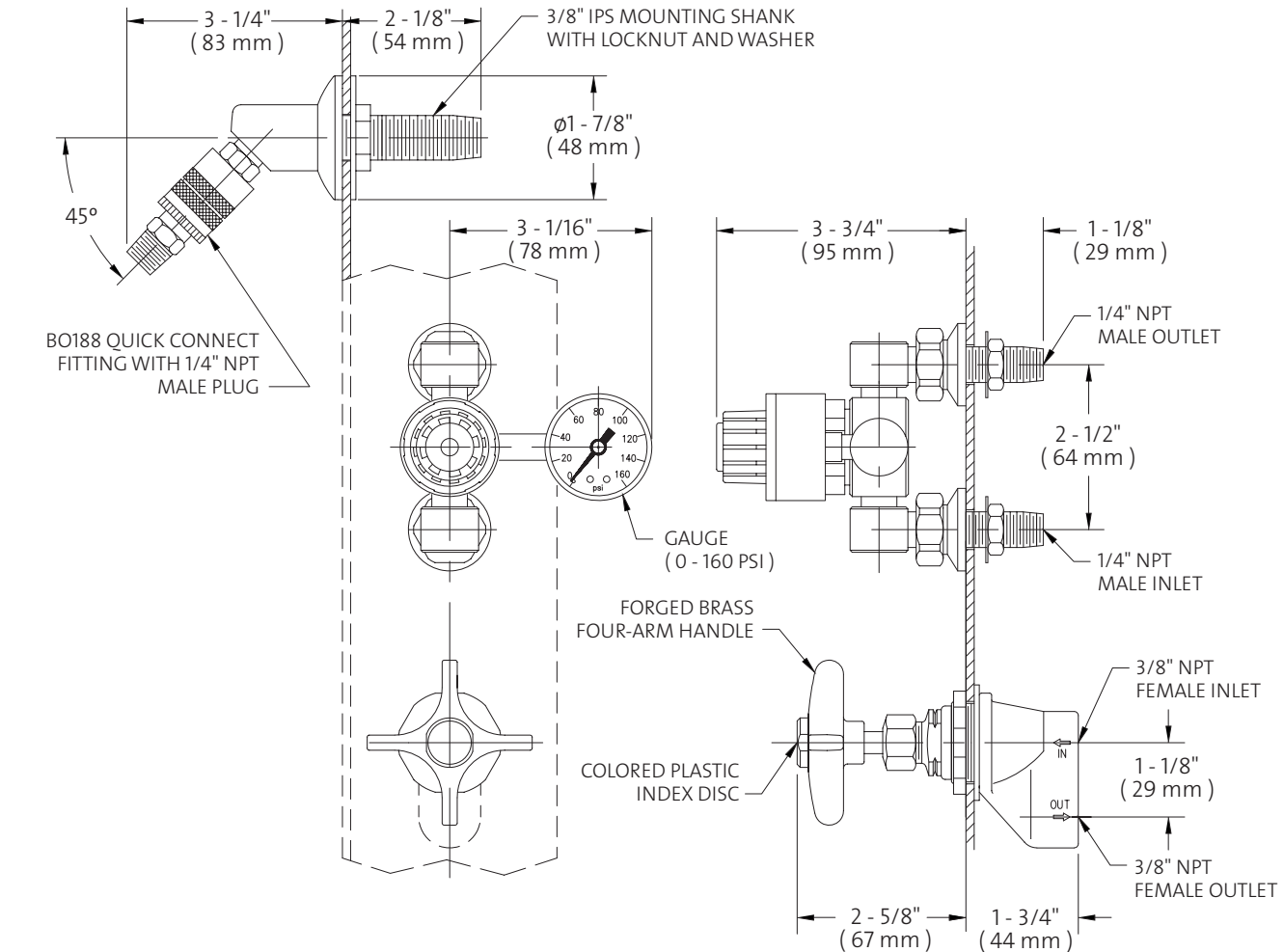

NOTES:

1. VALVE IS FACTORY ASSEMBLED AND TESTED AT 375 PSI HELIUM PRESSURE. MAXIMUM WORKING PRESSURE IS 250 PSI.
2. FIXTURE IS CLEANED, DEGREASED AND PACKED FOR PURE GAS SERVICE.
3. PROVIDE $\phi 1-1/4$ " MOUNTING HOLE FOR VALVE.
4. PANEL THICKNESS NOT TO EXCEED $1/8$ ".